

Technical Specification

DHF TS 008:2022+A1:2025

Enhanced security and general requirements for letter plate assemblies and slide through boxes

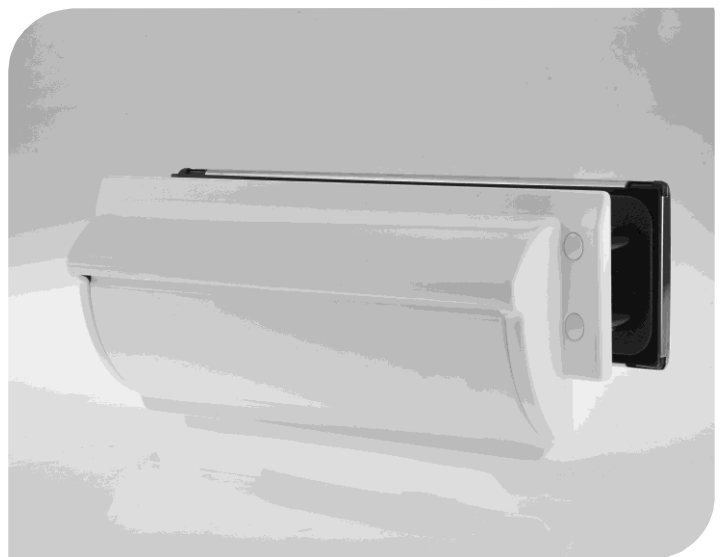

Contents

Foreword	3
1. Scope	3
2. References	3
3. Terms and definitions	4
4. Classification	5
5. General requirements	6
6. Test procedures - General	7
7. Classification requirements and test procedures	7
8. Specimen selection and test sequence	11
9. Marking and labelling	13
10. Installation instructions and fixing details	13
11. Reporting	14
ANNEX A - Test equipment (Normative)	15
Figure 1 - Manipulation test	15
Figure 2 - Target disc	16
Figure 3 - Manipulation test gauge (sheet 1)	16
Figure 3 - Manipulation test gauge (sheet 2)	17
Figure 4 - Fishing test	18
Figure 5 - Fishing test gauge	18

Foreword

This amendment replaces TS 008:2022 which is now withdrawn. The principal changes relate to:

- Updating normative references
- Re-defining Letter Flap
- Limiting the applied force on Gauge Mail No.2
- Increasing the allowable force to open the flap
- Adding tool No.10 (from PAS 24)

The document provides a classification for the enhanced security and general requirements for letter plate assemblies and slide through boxes. This technical specification provides a means of evaluation against opportunist attack. Additionally, attempts may be made to try and prevent the contents being removed and assess the product against potential arson attack.

A classification system for products conforming to this specification is provided in clause 4.

In view of the security nature of this technical specification, users are strongly advised to consider the desirability of third-party certification, inspection and testing of products conforming to this technical specification. Appropriate conformity attestation arrangements are described in BS EN ISO/IEC 17065:2012.

Sidelines have been introduced to identify the changes from the previous version.

1. Scope

- 1.2 This technical specification defines the requirements for classification of enhanced security and general requirements for letter plate assemblies and slide through boxes as defined below:
- letter plate assemblies that allow mail to pass directly through a door or side panel
 - slide through boxes that allow mail to pass directly through a door or door side panel
- and which are designed for fire and/or non-fire applications.

This technical specification is applicable to letter plates and slide through boxes intended for installation in doors and door side panels of any materials and, in specific cases, doors and side panels of particular materials.

Slide through boxes, where the receptacle from which mail is retrieved is in a communal area, are excluded.

NOTE: See TS 009 for products mounted entirely externally to the building.

- 1.2 This technical specification applies to complete letter plate assemblies and slide through boxes placed on the market, either fully assembled or as a kit. It does not provide for classification of individual components, such as cowls, placed on the market separately.
- 1.3 This technical specification does not provide for classification against the European standard EN 13724.

2. References

Normative references

BS 476-22	Fire tests on building materials and structures. Methods for determination of the fire resistance of non-load bearing elements of construction
EN 1634-1	Fire resistance and smoke control tests for doors, shutters and openable window assemblies and elements of building hardware. Part 1 Fire resistance tests for doors, shutters and openable windows
EN 1634-2	Fire resistance and smoke control tests for door, shutter and openable window assemblies and elements of building hardware. Fire resistance characterisation test for elements of building hardware

EN 1670: 2007 +Corrigendum 2008	Building hardware corrosion resistance - requirements and test methods
EN 12209: 2016	Building hardware. Mechanically operated locks and locking plates. Requirements and test methods
EN 13724: 2013	Postal services - Apertures of private letter boxes and letter plates - requirements and test methods
EN 15947	Pyrotechnic articles - Fireworks, Categories F1, F2 and F3
EN ISO/IEC 17065:2012	Conformity assessment. Requirements for bodies certifying products, processes and services
PAS 24: 2022+A1:2024	Enhanced security performance requirements for doorsets and windows in the UK

3. Terms and definitions

- 3.1 **Attack side**
The external face of the test specimen detailed for attack.
- 3.2 **Attack time**
Time allowed for attack and manipulation of the specimen using the referenced tool kit in order to make target/gauge points accessible.
- 3.3 **Burglar resistance**
To resist forced entry, using physical force and predefined tools.
- 3.4 **Fishing**
Any method allowing the removal of any item other than post from within the building via the letter plate, usually using items to extend the reach beyond that of a human arm.
- 3.5 **Fixing - through fixing**
A letter plate that is primarily secured by means of a bolt or screw from the inside of the door to a captive nut or similar on the outer part of the letter plate.
- 3.6 **Fixing - face fixing**
A letter plate that is primarily secured by means of fixings between the outer part of the letter plate to the outer face of the door.
NOTE: Where the door construction is unknown, through fixings may be more reliable.
- 3.7 **Fully functional**
The letter plate assembly or slide through box assembly shall operate normally with the specimen meeting the gauge mail test (cl: 5.2) and opening force of the flap (cl: 5.3) and EN 13724 (cl: 5.4.4 Closing of the flap).
- 3.8 **Gauge mail**
Items used to test the clear delivery of post items. As specified in EN 13724:2013 cl: 5.3.3 Gauges 1 and 2.
- 3.9 **Letter box**
A receptacle into which mail is delivered.
- 3.10 **Letter box assembly**
A letter box and letter plate either fully assembled or in kit form.
- 3.11 **Letter flap**
Any moveable component, whose purpose is to cover and/or seal the aperture.

- 3.12 **Letter plate**
Aperture with a letter flap, sprung or unsprung, located on door or door-side-panel consisting of: a frame, a letter flap and installation materials.
- 3.13 **Letter plate assembly**
Letter plate and its associated security hardware, which may be fitted remotely from the letter plate and which prevents access to the doors' locking system and/or fishing.
- 3.14 **Location**
Area described by a circle with a radius of 50 mm from a selected point.
- 3.15 **Manipulation**
Attack applying only a sufficient force to explore potential vulnerable areas without permanent set or plastic deformation of any tool.
- 3.16 **Overall test time**
Total time allowed for the test which includes a predetermined attack time and a remaining time which shall be used for attempts to fail the test specimen using the gauges specified.
- 3.17 **Remotely fitted security hardware**
Any component which contributes to the security performance of the product and is not attached to the letter plate when installed according to the manufacturer's instructions.
- 3.18 **Slide through box**
A letter box assembly where delivery and retrieval are from opposite sides of a door or panel.
- 3.19 **Test block**
Timber, PVC-U or composite block or door leaf in which the test specimen is mounted.
- 3.20 **Test rig**
Framed construction into which the test block containing the test specimen can be mounted.
- 3.21 **Test specimen**
Complete full working assembly ready for test.
- 3.22 **Tool kit**
Defined set of tools allocated for use in particular attack methods.

4. Classifications

Each product conforming to the requirements of this technical specification shall be classified according to the classification characters identified below. 'No performance determined' (NPD) is an option in specific clauses.

- 4.1 **(1st Digit) Product type**
A = Without any remotely fitted security hardware
B = With remotely fitted security hardware
- 4.2 **(2nd Digit) Aperture type**
1 = Letter plate assemblies
2 = Slide through box
- 4.3 **(3rd Digit) Enhanced security level**
1 = Removal of post and resistance to thumb-turn manipulation
2 = Removal of post, resistance to thumb-turn manipulation and fishing
- 4.4 **(4th Digit) Option to lock the letter plate to prevent delivery of mail**
N = No, not lockable
Y = Yes, lockable

4.5 **(5th Digit) Corrosion**

3 = 96 hours
4 = 240 hours
5 = 480 hours

4.6 **(6th Digit) Resistance to water penetration**

N = No performance determined
Y = Pass

4.7 **(7th Digit) Fire resistance**

0 = No fire resistance
1 = Yes

4.8 **(8th Digit) Arson attack**

Grade 0 = No performance determined
Grade 1 = Yes

Example of classification:

1	2	3	4	5	6	7	8
Product type	Aperture type	Security level	Option to lock	Corrosion	Water	Fire	Arson
B	2	2	Y	3	Y	0	0

5. General requirements – All letter plate assemblies and slide through boxes

5.1 The maximum aperture size shall be 260mm x 40mm. This shall be verified on the specimens mounted as required for the enhanced security test and prior to conducting that test.

5.2 The letter plate assembly or slide through box shall comply with the gauge mail requirements in EN 13724:2013 clauses 5.3.3. and 6.3 (Gauges 1 and 2). This test shall be conducted on the specimens mounted as required for the enhanced security test. Force applied to Gauge 2 shall not exceed 30 N.

5.3 The force required to fully open the flap shall not exceed 12 N.

5.4 All letter flaps shall be self-closing after a post item has been delivered as required by EN 13724:2013 clauses 5.4.4 and 6.4.4.

5.5 The letter plate assembly or slide through box assembly shall comply with EN 13724:2013 cl:5.7.6 and cl:6.7.6 when amended as follows:

EN 13724:2013 5.7.6 Security - type 4

The fixings and flaps shall remain intact when tested in accordance with 6.7.6.2 and 6.7.6.3.

After the tests according to 6.7.6.2 and 6.7.6.3 the letter plate assembly or slide through box assembly shall be fully functional.

EN 13724:2013 6.7.6 Security - type 4

6.7.6.1 General

The letter plate assembly or slide through box shall be installed in accordance with Section 8 of this document.

EN 13724:2013 6.7.6.2 Fixings

The load shall be continuously increased without shock up to 0.5 kN. The load of 0.5 kN shall be held for 10s. The test shall be performed at each end of the frame (see Figure 9).

NOTE: these loads may differ from those in EN 13724.

EN 13724:2013 6.7.6.3 Flap

The load shall be continuously increased up to 0.5 kN. The load shall be applied without shock to the letter flap, such that the force acts directly in shear with the pivot pin. The load of 0.5 kN shall be held for 10s. The test shall be performed at each pivot pin (see Figure 10).

NOTE: these loads may differ from those in EN 13724.

The test shall be carried out for both internal and external letter flaps. Inward opening letter flaps (letter flaps that open into the body of the door leaf) shall not be tested.

5.6 Durability test

The letter plate assembly or slide through box shall withstand a durability test of 20,000 cycles. At the completion of the test, it shall remain fully functional. Cosmetic damage is permitted.

Mount the letter plate assembly or slide through box rigidly within a suitable test block. The letter flap shall be opened to its fully open position. The letter flap shall then be allowed to return to the closed position under its normal action. A cycle is deemed to be from the closed to the fully opened position and back to the closed position.

During the first part (opening) of the durability test, force exerted on the letter flap shall not exceed that seen during normal usage.

Where internal and external letter flaps have a different construction, then both letter flaps shall be tested. Where internal and external letter flaps have the same construction, only one need be tested.

6. Test procedures – general

6.1 Throughout this specification the following tolerances shall apply, unless otherwise specified.

- mass in kilograms or grams (kg or g): $\pm 5 \%$
- length in millimetres (mm): $\pm 2 \%$
- force in kilonewtons or newtons (kN or N): $\pm 2 \%$
- torque in newton metres (Nm): $\pm 5 \%$
- time in seconds (s): $\pm 10 \%$
- temperature in degrees Celsius ($^{\circ}\text{C}$): $\pm 2 \text{ }^{\circ}\text{C}$

6.2 Where a letter plate assembly or slide through box is of a non-standard design such that using any of the test methods in this specification is not practical, this shall be referred to the **dhf** for an interpretation of this specification.

7. Classification requirements and test procedures

The main purpose is to prove the enhanced security & general requirements for letter plate assemblies and slide through boxes, grading the product when it is in its normal working environment.

7.1 Product type

Products that comply with this specification without any remotely fixed security hardware shall be graded A.

Products which need remotely fitted security hardware to comply with this specification shall be graded B.

This shall be determined by visual inspection.

7.2 Aperture type

This shall be determined by visual inspection.

7.3 Enhanced security

Products complying with test A (removal of post) and test B (manipulation) will be classed as grade 1. Products complying with test A (removal of post), test B (manipulation) and test C (fishing) will be classed as grade 2.

The test rig shall consist of a rigid frame capable of supporting test specimens of various dimensions. The frame shall not deflect more than 5 mm in any plane during testing.

For testing purposes, the test specimen (gauge point) shall be mounted at a height of 1000mm +/- 50mm.

Lockable letter boxes shall be unlocked.

The attack tests will normally be recorded with a video recorder. The recording shall be retained by the test laboratory in line with its normal retention policies. It may be made available to the client but it shall not be published or made publicly available.

7.3.1 Test team

The test team shall be a minimum of two testers. One of the testers shall be experienced in the attack testing of security products.

Each individual test shall be undertaken by one single tester. Different attacks may be undertaken by different testers, provided each separate attack is conducted by only one individual.

Non-destructive pre-testing and examination may be conducted by the test team to establish weak and vulnerable areas and to gain full knowledge of the test specimen's construction.

7.3.2 The burglar resistance attack methods used by the test team shall, in their opinion, and based on the non-destructive pre-test and examination, be the most likely to defeat the product for the grade of security requested by the applicant.

The tool kit available to the testers is as follows:

		PAS 24 clause
1.	Assorted mild steel wire, not more than 2 mm in diameter and not more than 700 mm in length	A.2.1.1
2.	Two credit cards, of size [(55 ±5) × (85 ±5)] mm and (0.7 ±0.3) mm thick	A.2.1.2
3.	Two paint scrapers, with a blade width of approximately (75 ±15) mm in width	A.2.1.3
4.	One craft knife, with a maximum overall length of 180 mm, a straight blade (0.6 ±0.1) mm thick and an exposed blade of length (28 ±7) mm, e.g. a Stanley-trimming type knife	A.2.1.4
5.	Two flat blade screwdrivers, of length (150 ±20) mm overall, a shank length of (75 ±15) mm, a shank diameter of (3 ±0.5) mm and a blade width of (3 ±1) mm. The shank shall be of vanadium or chrome tool grade steel	A.2.1.5
6.	One flat blade screwdriver, of length (200 ±20) mm overall, a shank diameter of (6 ±1) mm and a blade width of (6 ±1) mm	A.2.2.3
7.	One crosspoint screwdriver, of length (200 ±20) mm overall, a shank diameter of (6 ±1) mm and point size 2	A.2.2.5
8.	One cross head screwdriver, of length (200 ±20) mm overall, a shank diameter of (6 ±1) mm and point size P(Z)2, e.g. a Posidrive screwdriver	A.2.2.6
9.	Self-gripping pliers a) Straight jaw self-gripping pliers, with a nominal length between the end of the fixed jaw and the non-adjustable section of the handle of (210 ±10) mm b) Curved jaw self-gripping pliers, with a nominal length between the end of the fixed jaw and the non-adjustable section of the handle of (210 ±10) mm in length	A.2.3.1
10.	One interchangeable bit screwdriver, of length (200 ± 20) mm long overall with PH1 to PH3, PZ1 to PZ3, T5 to T30, H2 to H6, hexagon heads range 4 mm to 10 mm and slotted 3.5 mm to 6.5 mm bits. This screwdriver is only to be used for the removal of exposed fixings.	A.2.3.7
11.	Set of small screwdrivers with various head designs, (maximum 100 mm overall length with a shaft diameter 6 mm +/- 2 mm) Head forms as EN 12209 cl: 4.1.8. i.e. Slot, Phillips, Posidrive, Hex socket, (Allen), Torx, Torx pin, Hex bolt	
12.	Set of spanners (maximum length of 180 mm) (not to be used for levering)	
13.	Set of hexagon Allen keys (maximum length of 120 mm) (not to be used for levering)	
14.	Long nose engineers' pliers (200 mm long +/- 10 mm)	
15.	Set of pin punches (100 mm long +/- 10 mm maximum diameter 8 mm)	

Where PAS 24 clause numbers are given, the definitive details of the tools can be found in PAS 24.

The tester may apply a force sufficient to explore any potential vulnerability but this force shall not result in permanent set or plastic deformation of any tool. Manipulation at any location shall be terminated if permanent set, plastic deformation or breakage of a tool occurs. Damaged tools shall be replaced and the test continued at other locations.

If access to the head of any threaded fastener becomes available, attempts to unscrew the fastener shall be made using the tools 5, 6, 7, 8, 10, 11, 12 and 13.

7.3.3 Specimen gauge point

The specimen gauge point is located horizontally on the centre line of the letter plate and vertically at the highest point of the lower surface of the letter plate aperture. As shown in Figure 1 and Figure 4.

7.3.4 Test A: Mail retrieval

Five envelopes of DL size shall be posted individually through the letter plate assembly or slide through box. Attempts shall be made to remove any of the five DL envelopes without the use of the tool kit and without causing damage. The overall test time allowed for test A is 60 seconds. The removal of any DL envelope shall be classed as a failure.

7.3.5 Test B: Manipulation test

The test specimen shall be mounted as shown in Figure 1. The target disc (Figure 2) shall be fitted on the inside face of the door 390 mm horizontally and 150mm above the specimen gauge point 1.

Using tools from the tool kit, the test specimen shall be attacked using various methods including manipulation of trim sections, undoing threaded fastenings etc; only one tool shall be used at any time. No attack shall be made on the substrate, with the exception of damage that may be caused from using the surface as a fulcrum.

The attack time shall not exceed 3 minutes within a total overall test time of 5 minutes.

The manipulation gauge shall be used only to make an assessment of accessibility and may not be used to apply force or attack the specimen. The positionable end of the gauge ("articulated finger") may be adjusted within the overall test time to facilitate contact with the target disc.

During the test, if it is not possible to make and maintain contact for five seconds using the gauge and the target disc within the overall test time, then the test specimen is deemed to have passed.

NOTE: In order to confirm that contact has been made and maintained for five seconds, it is suggested that the target disc, when touched with the test gauge tip on the contact area shown in Figure 2, could give a positive indication of contact using either an audible or visual signal (e.g. a buzzer or light).

7.3.6 Test C: Fishing test

The fishing gauge shall consist of an aluminium rod of 6 mm diameter x 1200 mm long. It shall have the provision for a steel disc of 20 mm diameter and weight of 0.075kg to be attached to the end of the aluminium rod as shown in Figure 5. The fishing gauge shall not be flexed or bent during the assessment.

The test specimen shall be attacked using the tool kit defined in 7.3.2, with the exception that the self-gripping pliers shall not be used. Only one tool shall be used at any time. No attack shall be made on the substrate except to the extent that the substrate may be damaged by being used as a fulcrum.

Following the attack, it shall not be possible for the fishing gauge to pass over a barrier placed parallel to and 900mm from the internal door face and 250mm below the gauge point.

If it is not possible for the fishing gauge to pass over the barrier, then the test specimen is deemed to have passed the test and no further testing is needed.

If it is possible for the fishing gauge to pass over the barrier, then the time shall be stopped and a disc of 20mm diameter and weight of 0.075kg will be permanently attached to the end of the aluminium rod as shown in Figure 5. Attempts shall be made to retrieve the rod and disc through the specimen to the external face of the door.

It is permissible to make further attacks on the test specimen during the second part of the test within the permitted overall attack time.

The test specimen is deemed to have passed the test if it is not possible to fully retrieve the rod and disc to the external face of the door within the overall test time of 5 minutes.

The attack time shall be 3 minutes within a total overall test time of 5 minutes.

- 7.4 Option to lock**
This shall be confirmed by visual inspection if the delivery of mail is prevented by optional locking devices. This performance of the option to lock is assessed with regard to whether the delivery of mail can be temporarily prevented by the optional locking device. Assessment of the effectiveness and security performance of products with the optional locking device engaged is outside of the scope of this technical specification.
- 7.5 Corrosion**
Evaluation shall be in accordance with the requirements of EN 1670: 2007 Corrigendum 2008 grades 3, 4 or 5.
Following the test, both internal and external letter flaps shall meet the EN 13724 requirement 5.4.3 Opening force of the flap. The force required to fully open the flap shall not exceed 12 N.
NOTE: For the purpose of this technical specification, the ability to operate after the test is the only criterion; appearance is not considered.
- 7.6 Water penetration**
Evaluation shall be in accordance with the requirements of EN 13724: 2013, clauses 5.6.2 & 6.6.2.
- 7.7 Fire resistance**
Testing shall be in accordance with BS 476-22, EN 1634-1 or EN 1634-2.
To comply with Box 7 (Fire Resistance) Grade 1, the letter plate shall achieve a performance of at least 30 minutes insulation and 30 minutes integrity when part of a specific doorset construction.
NOTE: this does not infer performance for a wider range of doorset constructions.
- 7.8 Arson attack**
There shall be a box, or other container, on the back of the letter plate assembly or slide through box to contain the potential fire from accelerants.
Petrol shall be contained within the box until the fire is extinguished.
There shall be no sustained flaming internally until the fire is extinguished. (Sustained flaming - flaming that is visible with the naked eye and that remains visible for an uninterrupted period of not less than 10s.)
- 7.8.1 Test methods**
The following series of tests are designed to provide information on the behaviour of letter plate assemblies under different exposure conditions, simulating potential methods of arson attack. These test scenarios are considered to be sufficient to demonstrate the ability of a composite assembly to contain and extinguish fires involving different materials under different ventilation conditions to prevent spread to the property.
The test specimen may be mounted in a fire resistance board to perform this arson attack and does not need to be fitted into plywood, brick, PVC-U or other materials.
- 7.8.2 Arson Test 1**
A quantity of typical envelopes and their contents weighing 100g are posted into letter plate assembly or slide through box. 500ml of petrol is then sprayed into the specimen using a squeezable bottle with a nozzle through the letter plate. The letter plate is propped open for the duration of the test to create the worst-case scenario in terms of ventilation. The envelopes are ignited through the letter plate.
- 7.8.3 Arson Test 2**
A quantity of typical envelopes and their contents weighing 36g are posted into the letter plate assembly or slide through box. The envelopes are then ignited through the letter plate using a rolled-up newspaper (approximately 150g) which is itself lit at one end. The lit end of the newspaper is inserted into the letter plate to ignite the envelopes. The rolled-up newspaper is left protruding from the aperture, holding the letter flap partially open.
- 7.8.4 Arson Test 3**
A single UKCA or CE marked category 2 firework rocket (EN 15947-1:2015 Pyrotechnic articles - Fireworks, Categories F1, F2 and F3) with a net explosive content of between 10-15g, shall have the stick cut short enough or removed to allow it to be posted through the door into the specimen. The fuse on the rocket shall be lit and the rocket posted through the letter plate. The letter flap shall be allowed to shut itself and the test continued until the firework is exhausted.

8. Specimen selection and test sequence

8.1 The applicant shall supply detailed information about the product to be tested including the following:

- Name and address of the manufacturer/supplier if different to the applicant
- Manufacturer's installation instructions
- Thicknesses of door or panel into which the product can be installed
- Specific materials of door or panel into which the product should be installed

8.2 The test specimens shall be supplied for testing fully functioning, complete with all hardware, accessories and fixings and shall be installed in accordance with the manufacturer's instructions.

8.3 The test specimens shall be visually examined for conformity with the details supplied by the client.

8.4 One specimen in each substrate shall be used for tests A and B, a second specimen in each substrate for test C.

NOTE: Only face fixed product is tested in the GRP substrate.

8.5 **Test Specimens Numbers 1 & 2 shall be supplied in either:**

Plywood or timber section of dimensions 44mm +/- 4mm x 850mm (min) x 200mm (min) having a minimum density of 600 Kg/m³ in accordance with BS 644:2012 (or a suitable equivalent).

or

Plywood or timber full door leaf of 44 mm +/- 4mm thickness having a minimum density of 600Kg/m³ in accordance with BS 644:2012 (or a suitable equivalent). For this option, the top panel or panels must be of transparent material.

Test Specimens Numbers 3 & 4 shall be supplied in either:

A typical 70mm thick PVC-U 3- to 5-chambered door profile without reinforcement and compliant with BS EN 12608:2003 class B, with a wide face dimension of 95mm (min) and length 850mm (min).

or

A typical 70mm thick PVC-U 3- to 5-chambered door leaf containing a horizontal mid rail with a profile without reinforcement and compliant with BS EN 12608:2003 class B, with a wide face dimension of 95mm (min). For this option, the top panel or panels must be of transparent material.

Test Specimens Numbers 5 & 6 shall be supplied:

In a composite door section with a GRP skin 3 mm +/- 1 mm thick with a polyurethane foam core with a maximum density of 100Kg/m³, and dimensions 44mm +/- 4mm x 850mm (min) x 200mm (min).

Test Specimen Number 8 shall be supplied.

Mounted in a 44mm +/- 4mm thick block of European redwood (or a suitable equivalent).

Where the manufacturer declares that the letter plate assembly or slide through box is suitable only for a specific material or door thickness, this shall be detailed in the fitting instructions and in the test report. The test authority shall be consulted regarding the test programme and sample requirements which shall ensure that all relevant door materials and thicknesses are evaluated.

NOTE: Where the letter plate assembly or slide through box has not yet attained a pass to TS 008, sample instructions and labels shall be supplied separately for assessment purposes.

Typical Specimen usage

Test specimen	Tests	Test block	Clause	Notes
1	Aperture dimensions	Timber	5.1	
	Gauge Mail		5.2	
	Self-Closing		5.3	
	Test A Mail Retrieval		7.3.4	
	Test B Manipulation		7.3.5	
2	Test C Fishing	Timber	7.3.6	Only required for enhanced security level 2
3	Aperture dimensions	PVC-U	5.1	
	Gauge Mail		5.2	
	Self-Closing		5.3	
	Test A Mail Retrieval		7.3.4	
	Test B Manipulation		7.3.5	
4	Test C Fishing	PVC-U	7.3.6	Only required for enhanced security Level 2
5	Aperture dimensions	Composite	5.1	Only face fixed product is tested in the GRP substrate
	Gauge Mail		5.2	
	Self-Closing		5.3	
	Test A Mail Retrieval		7.3.4	
	Test B Manipulation		7.3.5	
6	Test C Fishing	Composite	7.3.6	Only face fixed product is tested in the GRP substrate. Only Required for Enhanced Security Level 2
7	Water Penetration		7.6	If applicable
	Corrosion		7.5	
8	EN 13724 Strength Test		5.4	The test authority may request additional samples if required so it may carry out tests on separate samples
9	Durability Test		5.5	
10	Fire Resistance		7.7	Only required for Fire Resistance grade 1
11	Arson Attack		7.8	Only required for Arson Attack grade 1. Tests may be carried out on three separate samples

9. Marking and labelling

- 9.1 The letter plate assembly or slide through box shall be provided with a tamper evident label or permanent marking fixed to the item in a prescribed position.
- 9.2 The letter plate assembly or slide through box shall be provided with a tamper evident label or permanent marking fixed to the item in a prescribed position.
- 9.3 The tamper evident label shall be fitted at source of manufacture, not despatched separately.

9.4 Example of label:

TS 008:2022+A1:2025
Classification

1	2	3	4	5	6	7	8
Product type	Aperture type	Security level	Option to lock	Corrosion	Water	Fire	Arson
B	2	2	Y	3	Y	0	0

Company Name: Letter plates - R - US

Product Name /No. Number 1

10. Installation instructions and fixing details

- 10.1 Each letter plate assembly or slide through box shall be supplied with full installation instructions. Alternatively, instructions may be provided via a website, provided that a link to the appropriate location is included with the assembly. These instructions shall include the following:

- The manufacturer's/supplier's name
- The manufacturer's/supplier's contact details
- The product name/part number
- Thicknesses of door or panel into which the product can be installed
- Specific materials of door or panel into which the product should be installed
- Installation instructions
- TS 008 classification information

The following warning about fire resistance.

Where a letter plate assembly or slide through box is fitted into a fire rated door or panel, it is essential that its fire rating is the same or higher than the surround into which it is to be fitted. When considering the scope of a letterplate with fire performance for inclusion in a fire doorset, the scope shall be limited to what is proven by test, including the generic fire resisting door type/thickness used, the height/direction tested, and shall remain specific to the test standard adopted.

The following warning about installation locations.

TS 008 compliant letter plates provide resistance against various methods of theft. For optimum protection, the letterplate should be installed in line with the test methods described in TS 008.

11. Reporting

The final test report shall include the following information where applicable:

- The name and address of the applicant
- The name and address of the manufacturer if different from the applicant
- Details of the test specimen; this may be construction drawings, written details, photographs etc
- Thicknesses of door or panel into which the product can be installed
- Specific materials of door or panel into which the product can be installed
- Copy of the installation instructions
- The part number/name of the product/s
- Fixing details
- Any locking details
- Classification achieved

ANNEX A Test Equipment (normative)

- Figure 1 - Manipulation Test
- Figure 2 - Target Disc
- Figure 3 - Manipulation Test Gauge (Sheet 1)
- Figure 3 - Manipulation Test Gauge (Sheet 2)
- Figure 4 - Fishing Test
- Figure 5 - Fishing Test Gauge

Figure 1 – Manipulation Test

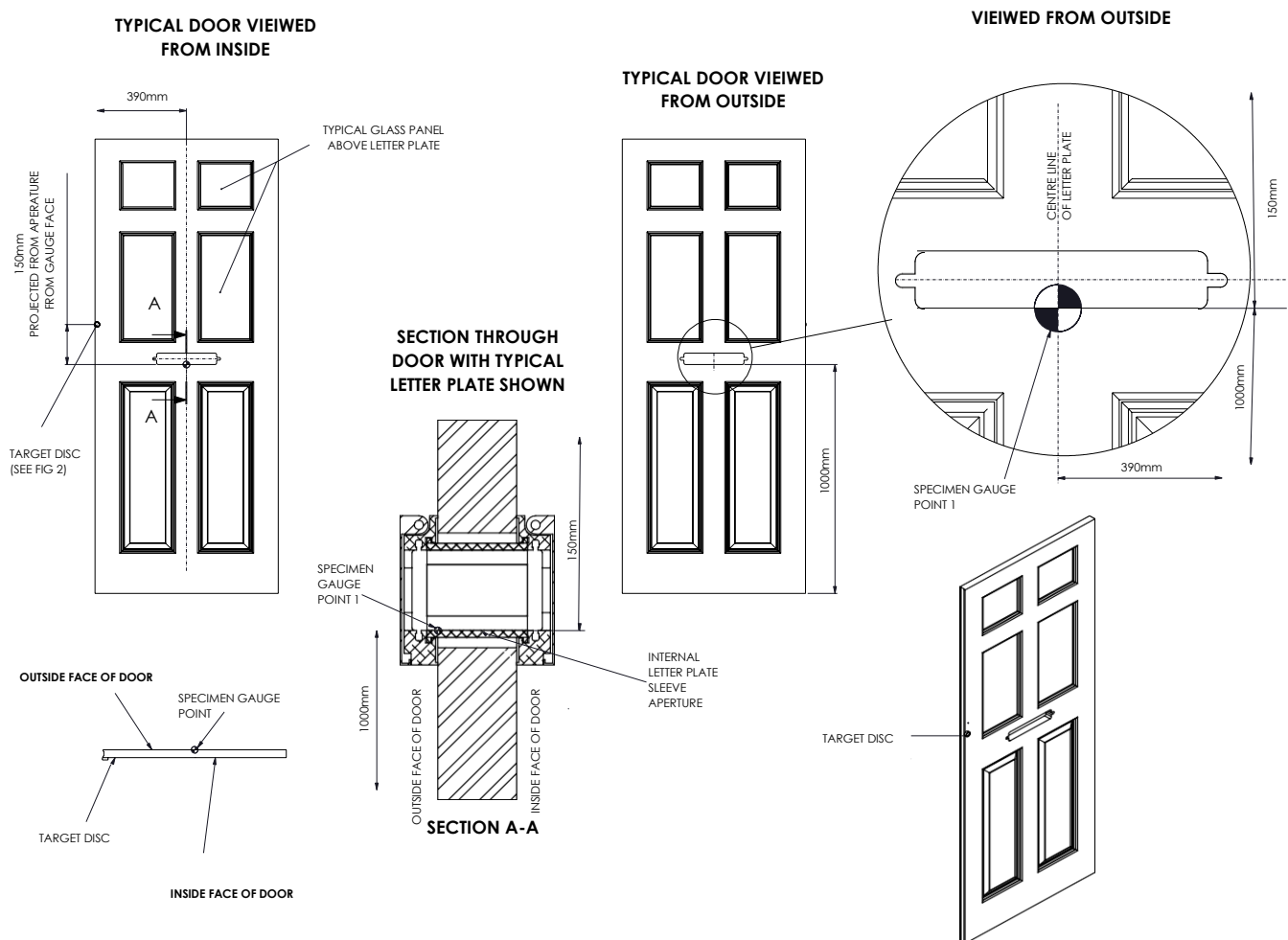

Figure 2 - Target Disc

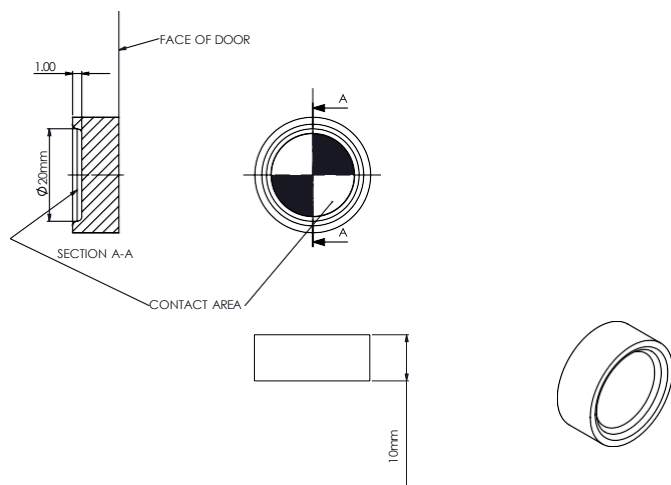

Figure 3 - Manipulation Test Gauge (Sheet 1)

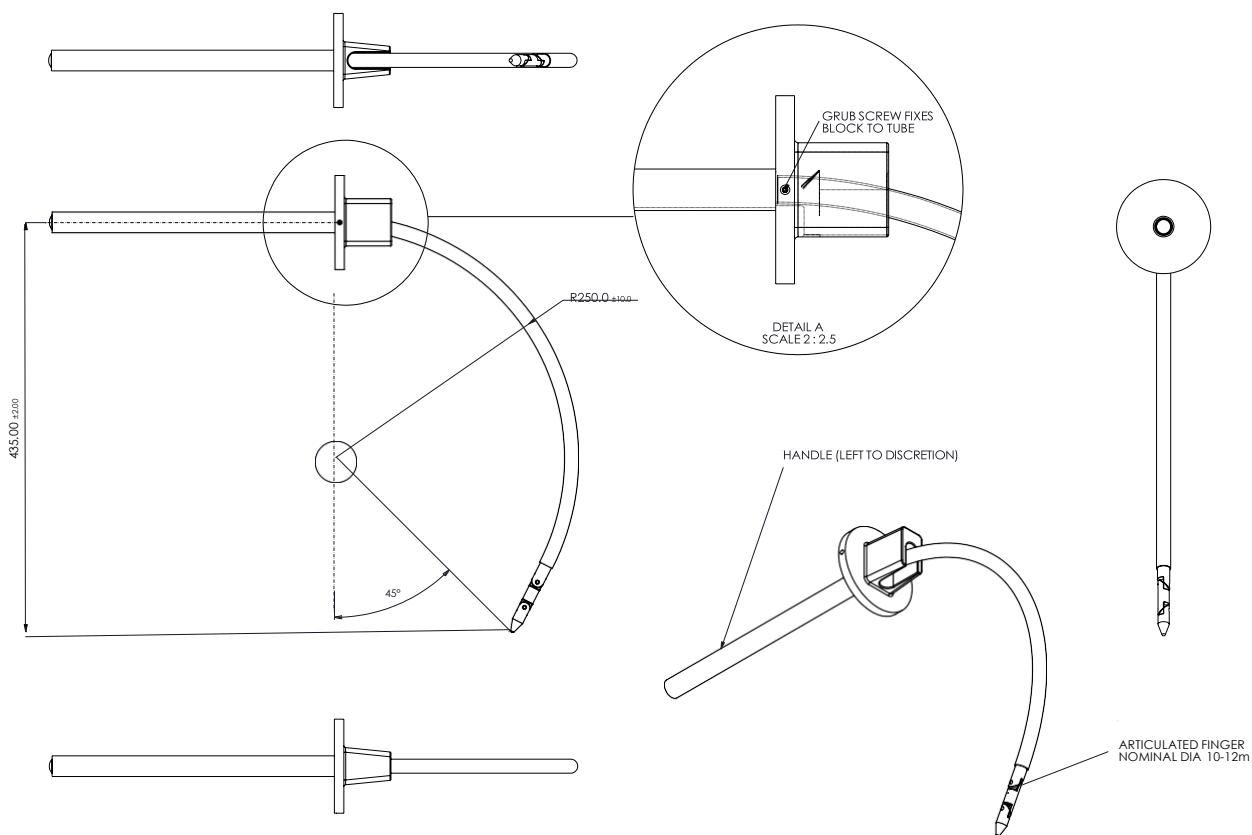

Figure 3 - Manipulation Test Gauge (Sheet 2)

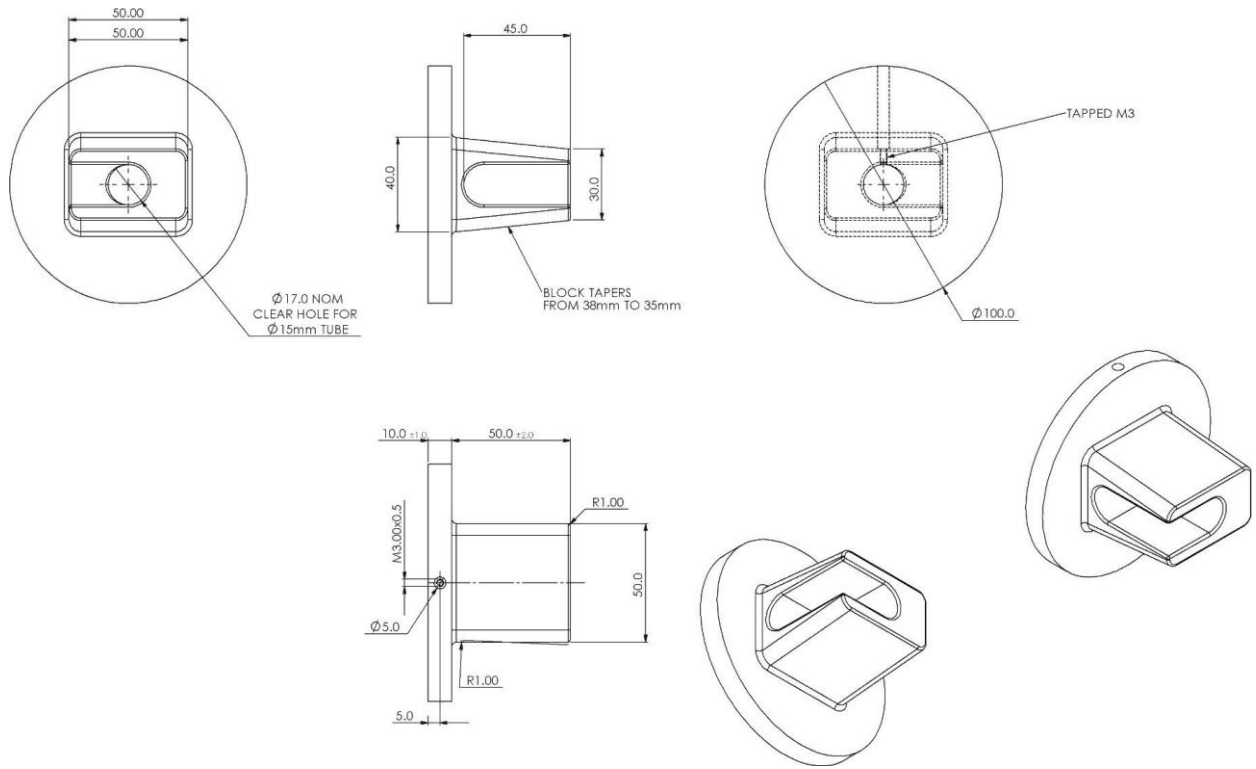

Figure 4 - Fishing Test

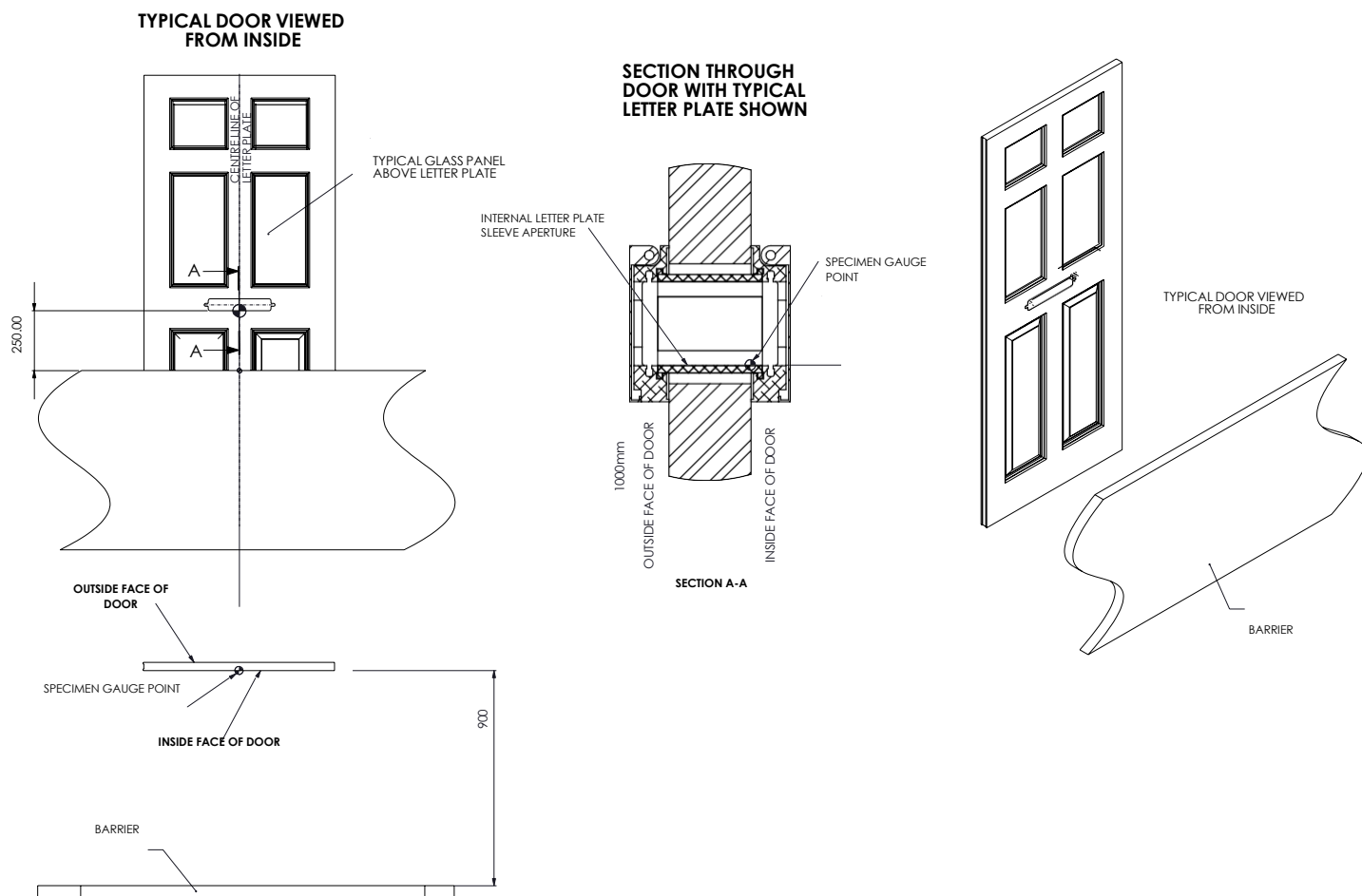
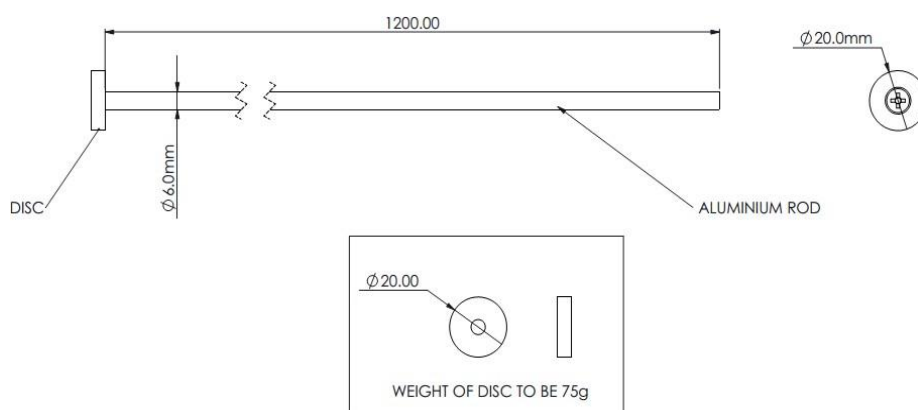

Figure 5 - Fishing Test Gauge







Contact us for more information



Email: info@dhfonline.org.uk

Telephone: (0)182752337

Address: **dhf** The Barn, Shuttington Fields Farm, Main Road, Tamworth B79 0HA

© Copyright **dhf** (Door & Hardware Federation) 2025

No part of this publication may be reproduced in any form without prior permission in writing from **dhf**. E&OE